



820301,820302,820303

OP SERIES

**2:1 RATIO TRANSFER PUMP
OPERATIONING MANUAL
WITH
PARTS IDENTIFICATION**



IPM, INC.

Manufactured by International Pump Manufacturing, Inc[®].

OP series

2:1 RATIO TRANSFER PUMP

OPERATIONS MANUAL and PARTS IDENTIFICATION DRAWINGS

This manual contains IMPORTANT WARNINGS and INSTRUCTIONS. Read and retain for future reference.

INTERNATIONAL PUMP MANUFACTURING, INC.

3107 142nd Avenue E Suite 106,

Sumner, WA 98390

U.S.A.

TEL: (253) 863 2222

FAX: (253) 863 2223

Website : www.ipmpumps.com

For Technical Service Call Your Local Distributor

Copyright 2016 by: International Pump Mfg, Inc.

WARNING: The equipment described herein must only be operated or serviced by properly trained individuals thoroughly familiar with the operating instructions, mechanics and limitations of the equipment.

Notice: All statements, information and data given herein are believed to be accurate and reliable but are presented without guarantee, warranty or responsibility of any kind expressed or implied. Statements or suggestions concerning possible use of IPM equipment are made without representation or warranty that any such use is free of patent infringement, and are not recommendations to infringe any patent. The user should not assume that all safety measures are indicated or that other measures may not be required. IPM reserves the right to make changes at any time without notice.

TABLE OF CONTENTS

1.0	SAFETY WARNINGS	4
	1.1 Pump and component grounding procedures	7
2.0	INSTALLATION	9
	2.1 Pump installation/set-up	9
	2.2 Disassembly – air motor section	11
3.0	PARTS IDENTIFICATION	14
	3.1 Air motor section assembly (700004)	14
	3.2 Parts list for 820301,820302,820303 (Air motor section)	15
	3.3 Parts list for 820301 (Fluid section)	16
	3.4 Parts list for 820302 (Fluid section)	17
	3.5 Parts list for 820303 (Fluid section)	18
4.0	REPAIR KITS	19
5.0	TROUBLESHOOTING	20
6.0	TECHNICAL SPECIFICATIONS	21
7.0	PERFORMANCE	22
8.0	WARRANTY AND DISCLAIMER	24

1.0 SAFETY WARNINGS

Please read and observe all warnings contained in this operations manual before making any attempt to operate the equipment.

Warning

To reduce the risk of static sparking or splashing fluid in the eyes or on the skin, follow the **Pressure Relief Procedure** before flushing.

For your safety, read the **Fire or Explosion Hazard** before flushing and follow all the listed recommendations.

Misuse of equipment

Misuse of equipment can cause serious bodily injury. Use the equipment only for its intended purpose and do not attempt to modify it in any way. Care should be taken to prevent over pressurization of the pump, hose lines and accessories connected to it. Use only IPM designated parts for re-building or repairing this equipment. Use the pump only with compatible fluids. Improper use of this equipment could result in fluid being sprayed on the skin or in the eyes of user, serious bodily injury, property damage, fire or explosion.

Daily maintenance inspection should be made on pumps and equipment and all worn or damaged parts should be re-placed immediately. Do not use pumps, components or hose lines as leverage to move equipment to avoid damage and injury. Do not alter this equipment as doing so could cause it to function incorrectly and/or cause serious injury. Altering this equipment in any way will also void any and all warranty guarantees from the manufacturer.

Material & fluid compatibility

Always ensure the chemical compatibility of the fluids and solvents used in the fluid section of these pumps, hoses other components. Check the chemical manufacturer's data sheets and specification charts before using fluids or solvents in this pump to ensure compatibility with pumps, inner hose lining and outer hose covering.

Pressurized hoses

Because the hoses are pressurized they can present a danger should the fluid escape due to damage, worn parts or general miss-use. Escaping fluid can splash or spray operator, causing serious bodily injury and/or damage to equipment and property. Ensure that the hoses do not leak or rupture due to wear, misuse or damage.

Before each use, ensure that the fluid couplings are tight and all clips/pins/plugs are secured. Inspect the entire length of hose for wear, cuts, abrasions, bulging cover and/or loose connections. These conditions may cause the hose to fail and result in splashing or spraying of chemicals on the skin or in the eyes of operator and cause serious injury and/or property damage.

Pressure specification

The maximum working pressure of this equipment for fluids and air is *180 psi (12.5 bars)*. Ensure all equipment and accessories used with this pump are rated to withstand the maximum working pressure of this pump. Never exceed the maximum working pressure of the pump, hose lines or any other components attached to the pump itself.

Procedure for pressure relief

In order to avoid the risk of serious injury to operators from splashing/spraying chemicals, the following safety procedures should be used. This procedure should be used when shutting down the pump, performing general maintenance, repairing a pump or other components of the system, replacing components or when pumping operation is ceased.

- 1 Close the air valve to the pump.
- 2 Use the air bleed down valve (see INSTALLATION) to relieve the air pressure in the system.
- 3 Relieve the fluid pressure by holding a grounded metal pail in contact with the metal part of the fluid dispense valve and slowly opening the valve.
- 4 With a container ready to catch the fluid, open the drain valve (see INSTALLATION).
- 5 It is a good practice to leave the drain valve open until it is time to dispense fluid again.

If you are unsure that the fluid pressure has been relieved due to a blockage in a component or a hose, carefully relieve the pressure by carefully loosening the hose end coupling to allow the fluid pressure to escape slowly. After the pressure has been relieved, the fitting can then be removed and any blockages removed. If the pump is to remain idle for only a short period of time, it is not necessary to empty the wet cup.

Flush the pump before initiating operation

- 1 The pump is tested with lightweight DOP oil, which is left in to protect the pump parts. If the fluid you are pumping may become contaminated by oil, flush oil from pump with a compatible solvent before use. Follow the flushing instruction below.
- 2 When pumping fluids that set up or solidify, flush the system with a compatible solvent as often as necessary to remove build-up of solidified chemicals in the pump or hoses.
- 3 If the pump is being used to supply a circulating system, allow the solvent to circulate through the entire system for at least 30 minutes every 48 hours or more often if necessary to prevent settling and solidification of chemicals.
- 4 Always fill the wet-cup 1/2 full of throat seal liquid (TSL) or compatible solvent to keep the fluid from drying on the displacement rod and damaging pump throat packing.
- 5 Lubricate the throat packing frequently, when you are pumping a non-lubricating fluid or are shutting down for more than one day.

- 6 IPM transfer pumps incorporates a wet tube, the purpose of which is to prevent the buildup of chemical and dirt on the pump shaft which would damage the packing as the shaft reciprocates through them. This wet tube must be full when a pump that has not been thoroughly flushed and cleaned is stored outside the protected environment of a sealed drum as well as when the pump is in use. Should a pump be installed in a partially filled drum where the liquid level is below the top of the wet tube, the tube must be manually filled with the proper chemical prior to inserting into the drum.
- 7 Once a pump is committed to a particular chemical, it is good practice to identify which chemical a particular pump is designated for to eliminate the possibility of mix up and contamination.

Shut down & care of pump

For overnight shut down, follow the *Pressure Relief Procedure* (page 5). **Always stop the pump at bottom of the stroke to prevent the fluid from drying on the exposed displacement rod and damaging the throat packing.**

Hazards from fire or explosion

Hazards exist where sparks can ignite vapors or fumes from combustible chemicals or other hazardous conditions exist such as explosive dust, etc. These sparks can be created from plugging in or unplugging an electrical supply cord or from the static electricity generated by the flow of fluid through the pump and hose.

Every part of the equipment must be properly grounded to prevent static electricity from generating a spark and causing the pump or system to become hazardous. These sparks can cause a fire, explosion, property and equipment damage and serious bodily injury. Ensure that the pump and all components and accessories are properly grounded and that electrical supply cords are not plugged in or unplugged when these hazards exist.

Should any evidence of sparks or static electricity exist, discontinue pump operation immediately. Investigate the source of the static electricity and correct the grounding problem. Do not use the system until the grounding problem is repaired.

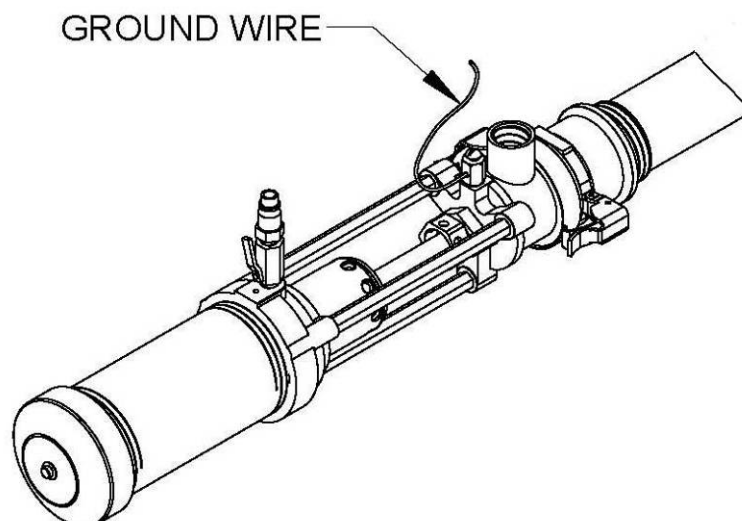

1.1 Pump and component grounding procedures

Always use the following procedures for grounding the pump. Loosen the lock screw to allow insertion of one end of a minimum size 12 gauge wire into the bore hole of the grounding lug. Insert wire and tighten the lock screw securely. Secure the other end of the ground to a true earth ground. Grounding of the pump and all components is necessary to minimize the possibility of sparks due to static electricity. Grounding must be in compliance with local electrical codes. Check with the local authorities for requirements in your area and with the type of equipment being used.

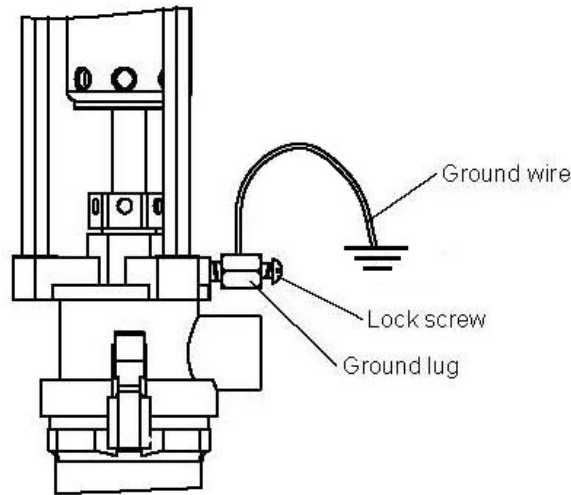

Figure A

Ensure that all the following equipment is grounded correctly:

1. Air compressor: Follow the grounding procedures as recommended by the compressor manufacturer
2. Air hoses: Always use grounded air hoses.
3. Fluid container used to supply the system: Grounding must be done according to local electrical codes.
4. Pump: Follow the procedures referred to in Figure A (page 6).
5. Fluid Hoses: Always use grounded fluid hoses.
6. Dispensing Valve: The valve must be metal to conduct through the fluid hose to the pump which must be properly grounded.
7. Dispensing Point: Grounding must be done according to local electrical codes.
8. Solvent Containers use only metal: Grounding must be done according to local electrical codes. Conductive pails that are properly grounded.
9. Grounding while dispensing, cleaning or relieving pressure: Maintain conductivity by firmly securing the metal part of the dispensing valve to the side of a grounded metal container.

Hose grounding

It is very important that the hoses used for both air and fluid dispensing be a grounding type and that ground continuity is maintained at all times during operation. Regular checks of the hose ground resistance (with a resistance meter using a suitable range) and a comparison to the manufacture's specification will ensure that the ground is within specifications. If it is not within specified limits it should be replaced immediately.

Solvent cleaning

While cleaning the system with solvent, secure the metal part of the dispensing valve in contact with a grounded metal pail to minimize the possibility of splashing/spraying of chemicals on the skin, in the eyes and around static sparks. Use low fluid pressure for additional safety.

Hazards from moving parts

Use the pressure Relief Procedure to prevent the pump from starting un-intentionally or unexpectedly. Be aware of moving parts that present a pinching hazard to fingers or other body parts. Stay clear of these moving parts at all times when starting or operating the pump.

Safety standards

Safety standards have been established by the United States Government under the Occupational Safety and Health Act. These standards should be consulted as they apply to the hazards and type of equipment being used.

2.0 INSTALLATION

Typical plural system configuration with drum mixer



Figure A - Set-up picture showing ISO and resin equipment installation with OP232C pump, OP242CD pump and drum mixer.

2.1 Pump installation / set-up

1. Use thread sealer on the male threads of the ball valve and quick disconnect plug. Install in the air inlet as shown.

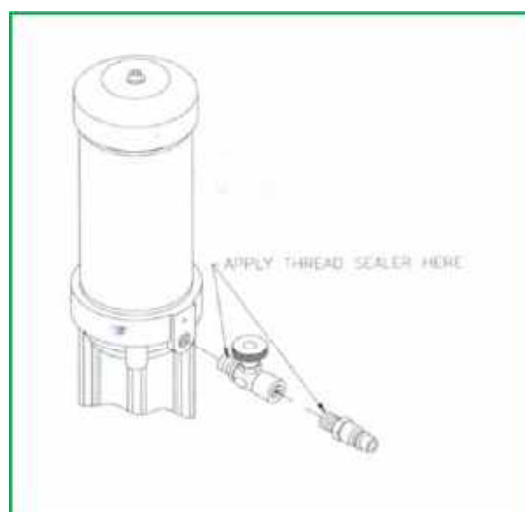

2. Screw the bung adapter onto the drum opening tightly. Carefully slide the transfer pump through the adapter and lock it in place with the bung adapter latch hooks.

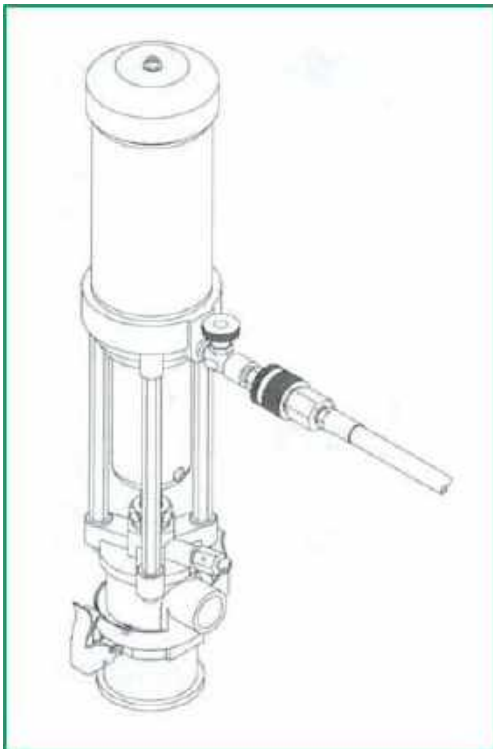
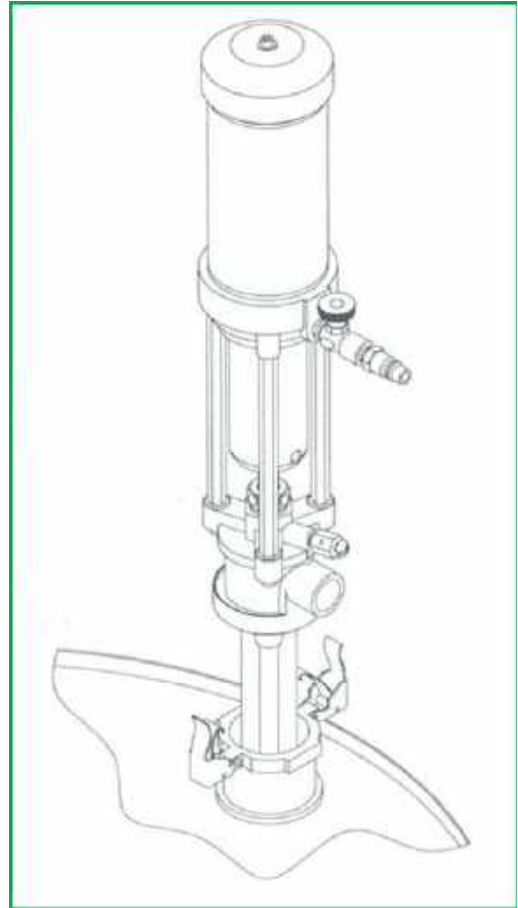

3. Attach air line onto quick disconnect fitting to complete installation. It is recommended to use a minimum 3/8" hose for the pump air supply.

2.2 Disassembly – air motor section

1. Disconnect all air and hydraulic pressure from pump for safety.
2. Place the pump in a vice being careful not to damage equipment. Pipe clamps will serve in the event you do not have a vice available.

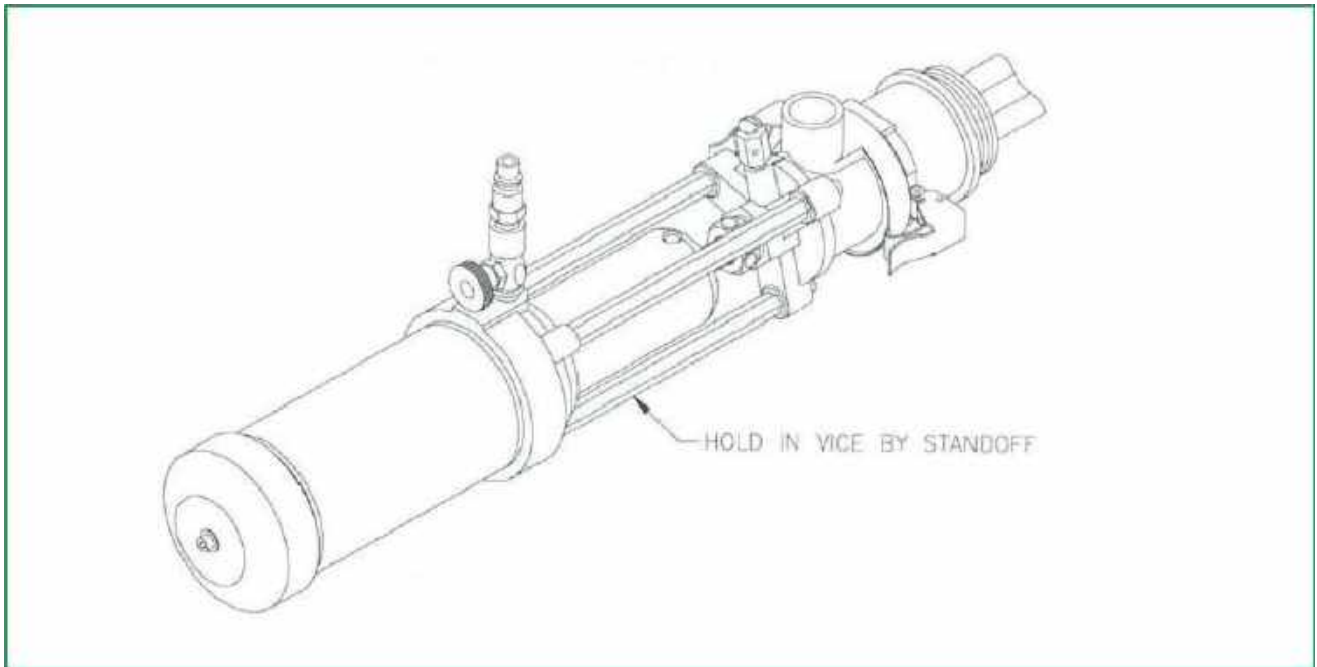

3. Remove the air bleed plug.

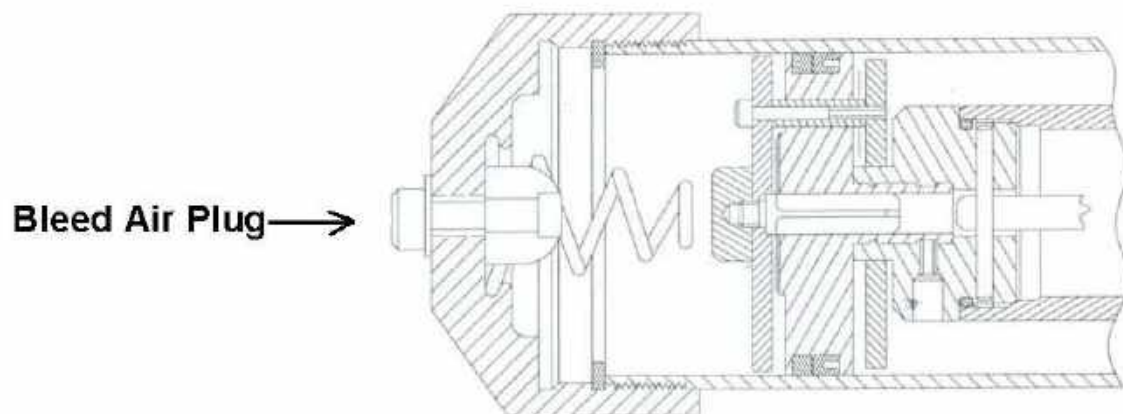

4. Place a strap wrench around the lower end of the air cylinder and carefully unthread.

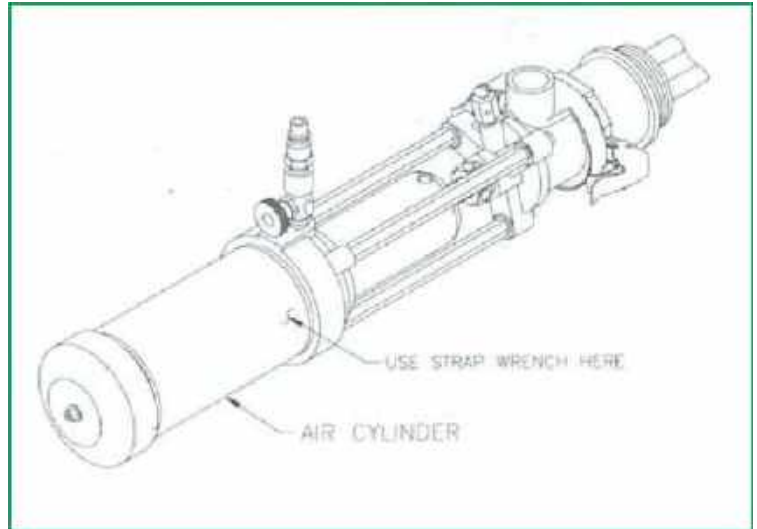

5. Use a 5/16" steel dowel pins to keep the piston rod plunger from rotating. Unthread.

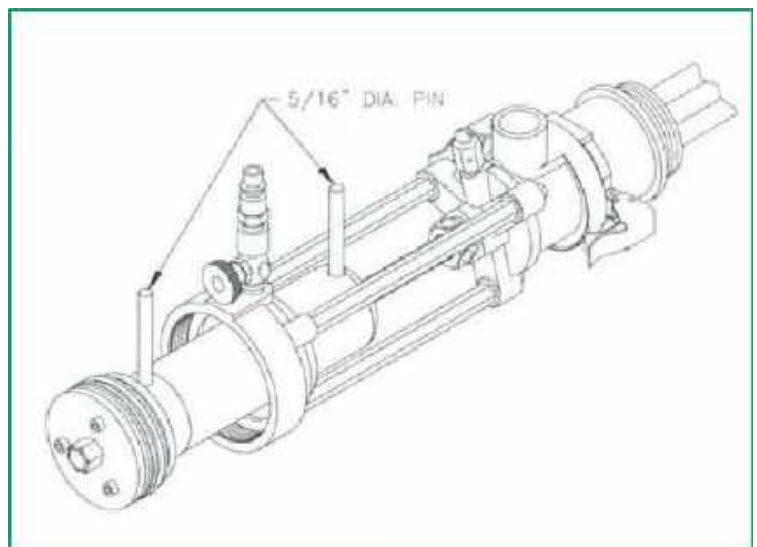

6. Remove the dowel pin from the plunger top. Air motor assembly can now be removed from the displacement plunger.

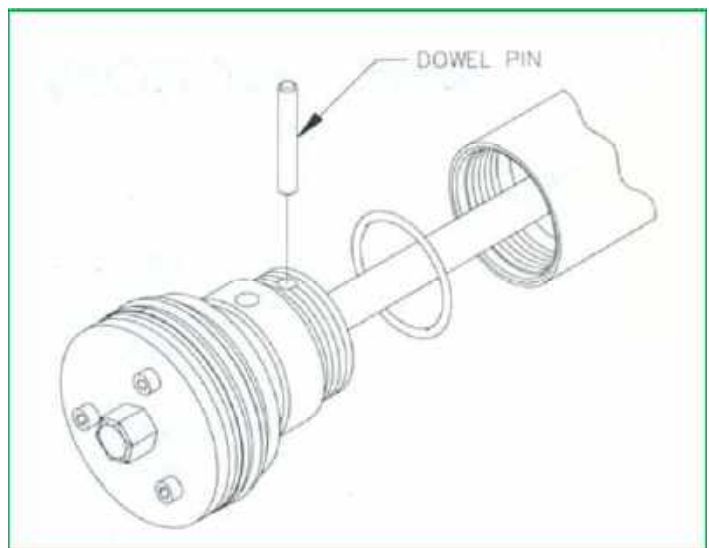

7. Push the piston out through the suction tube.

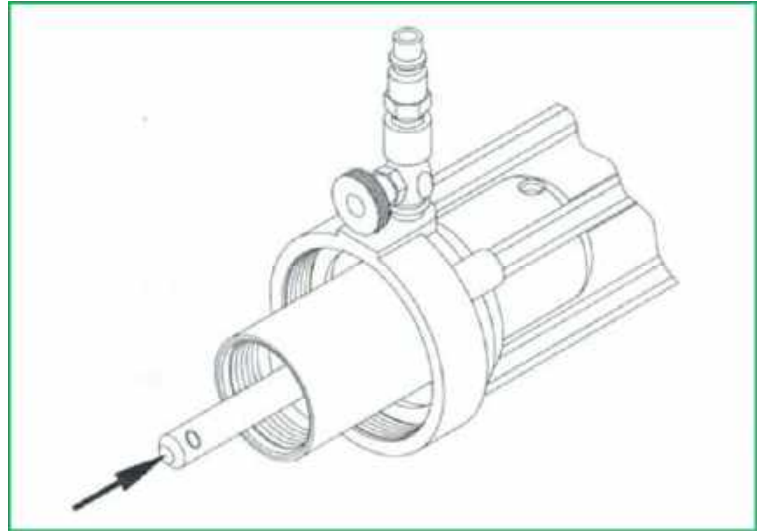

8. Inspect and replace the packings as required paying careful attention to the packing orientation.

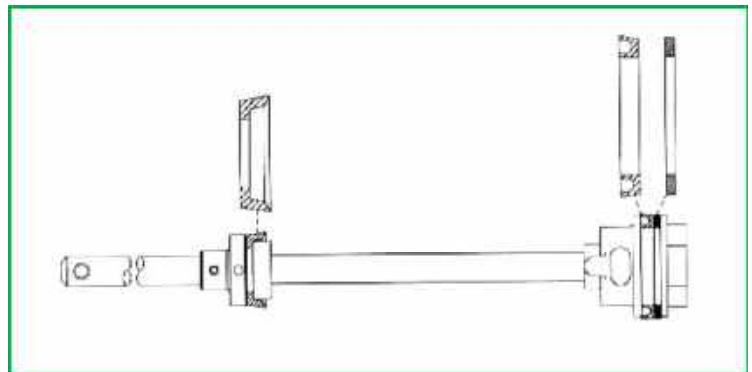

9. Lubricate, install, and assembly the parts in reverse order. Lubrication is recommended for use on the air cylinder walls and all of the components within the air motor assembly.

3.0 PARTS IDENTIFICATION

3.1 Air motor section assembly (700004)

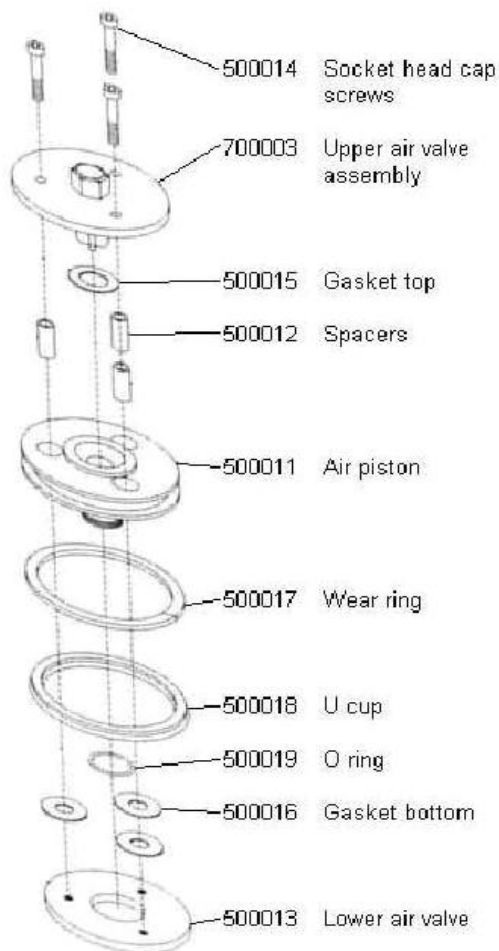

NOTE: When replacing Lower Air Valve (500013) and the Socket Head Cap Screws (500014), it is important that a Liquid Thread Sealing Compound be used to prevent the assembly from vibrating loose.

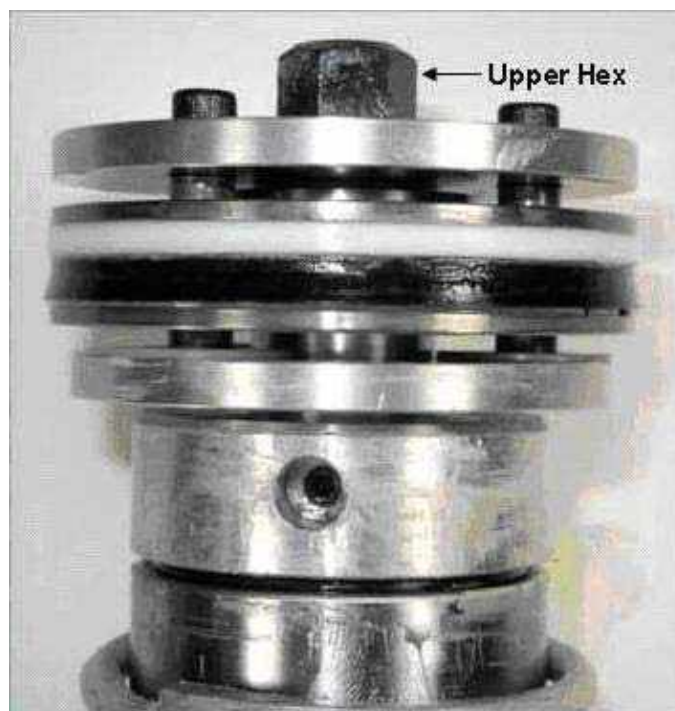

Note: Upper hex nut is a permanent of upper air valve plate (#700003). Do not use a wrench on hex nut during disassembly, assembly or maintenance of air motor assembly.

3.2 Parts list for 820301,820302,820303 (Air motor section)

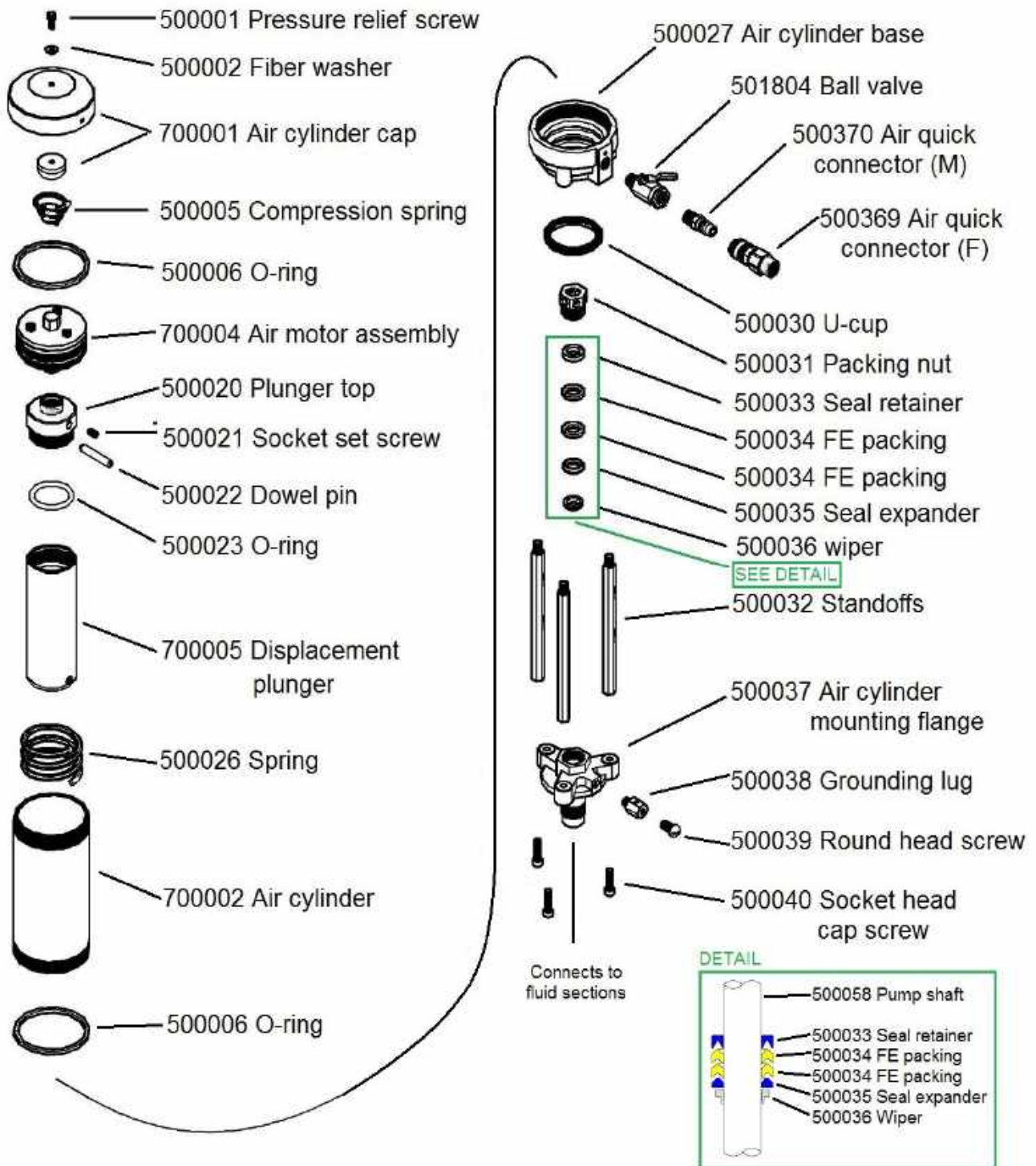

3.3 Parts list for 820301 (Fluid section)

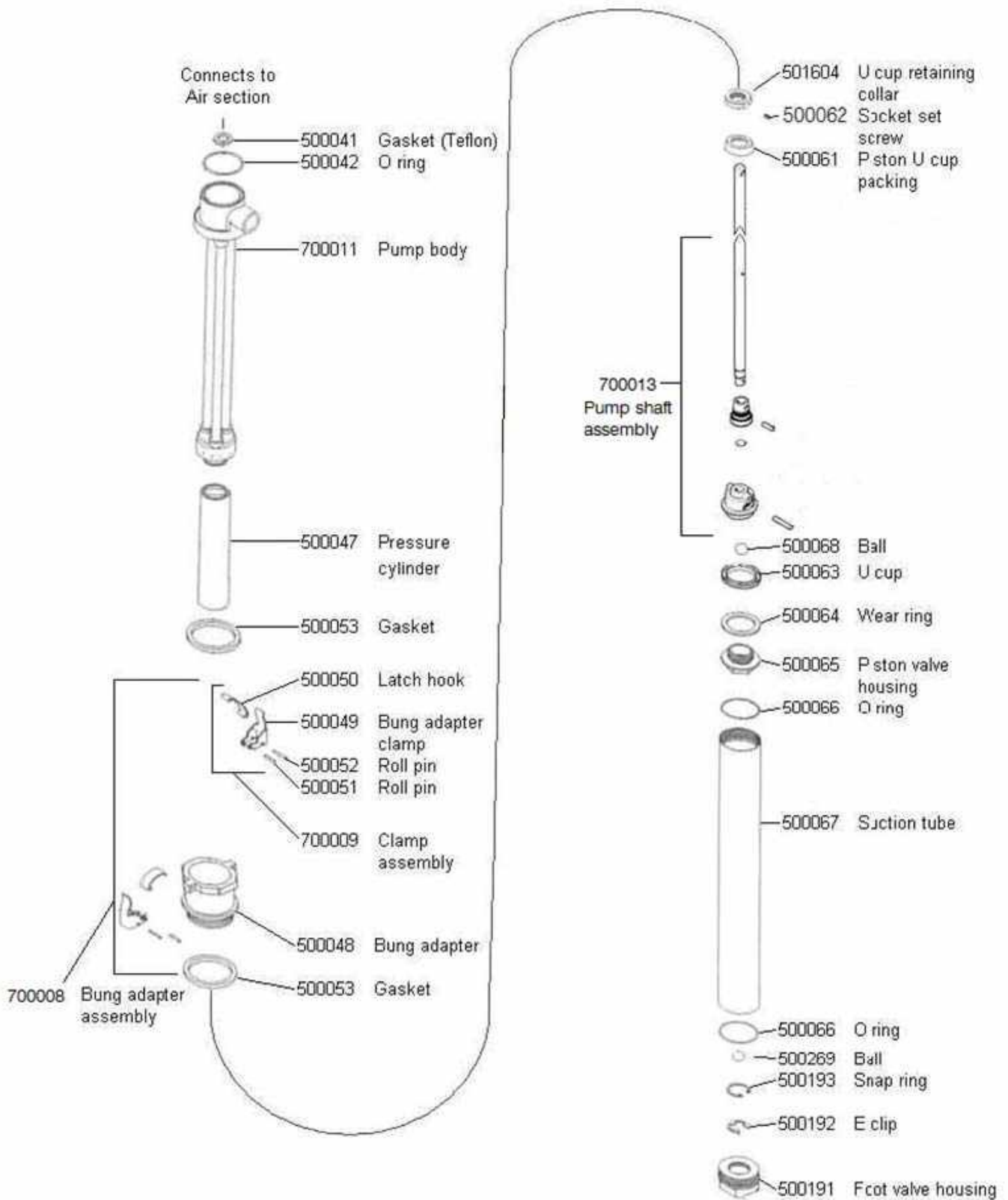

3.4 Parts list for 820302 (Fluid section)

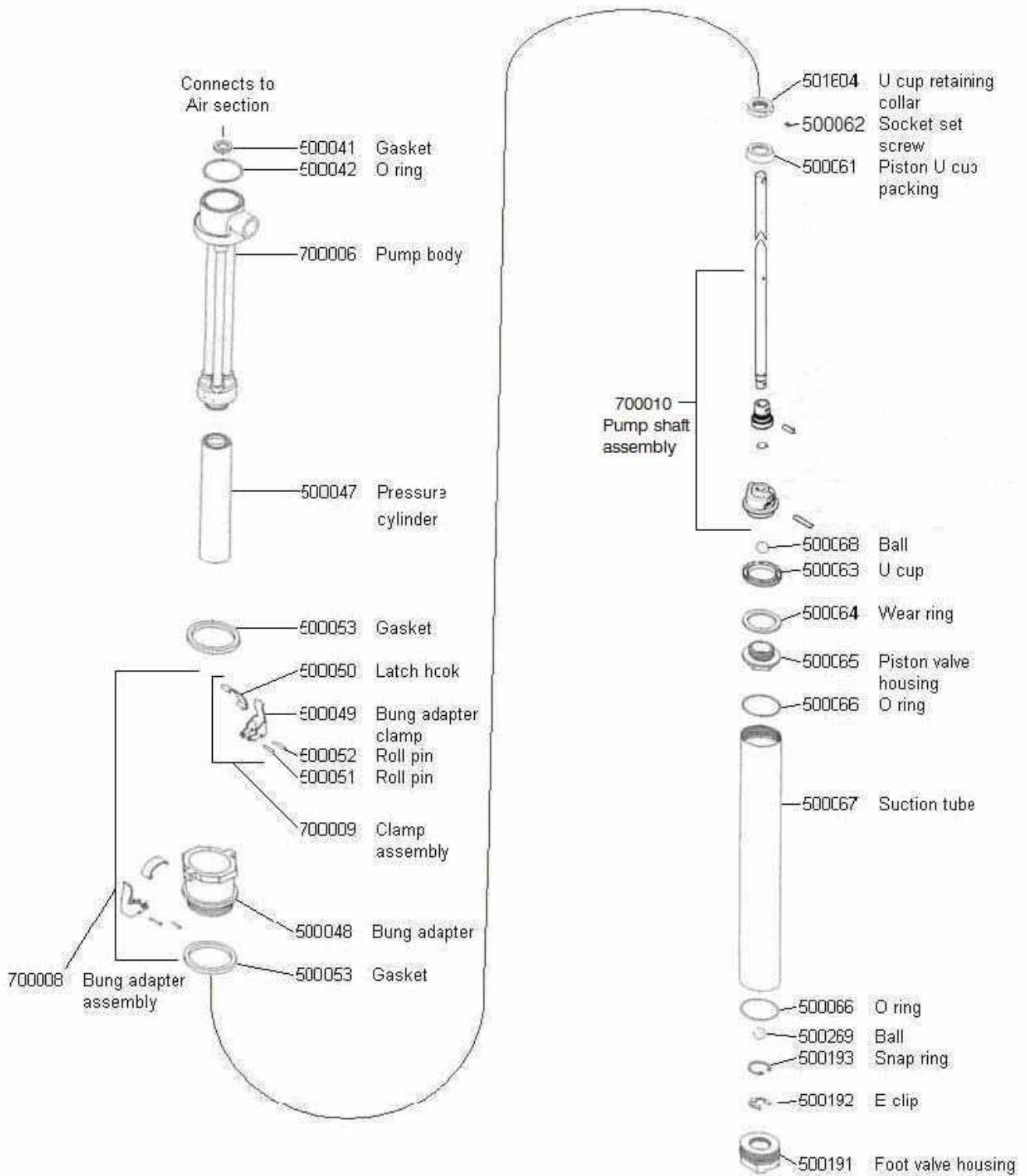

3.5 Parts list for 820303 (Fluid section)

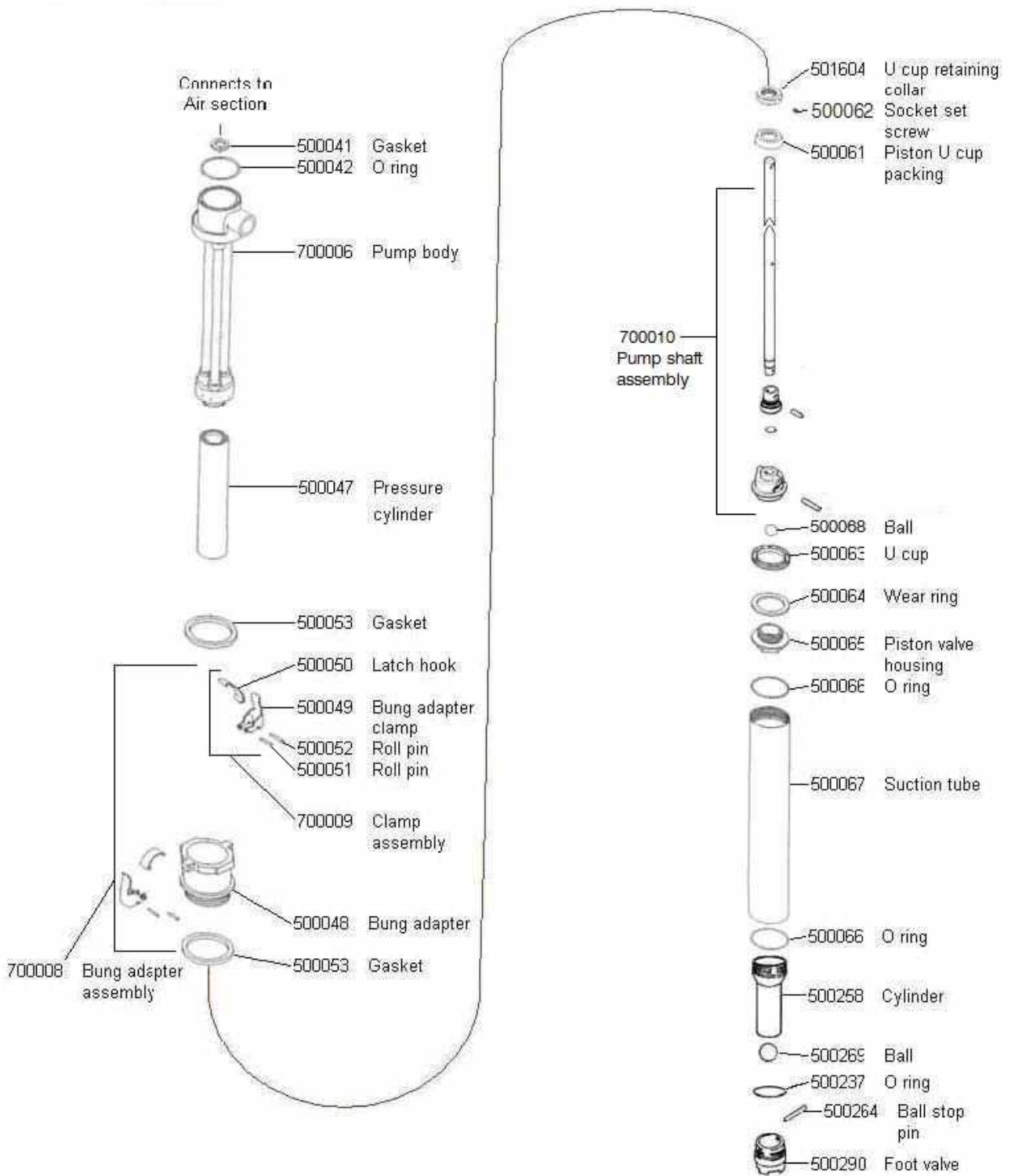

4.0 REPAIR KITS

601018	Air motor section repair kit		
	Fits: 820301, 820302, 820303		
	Components include		
	Part #	Description	Qty
	500006	O-ring	2
	500015	Gasket	1
	500016	Gasket	3
	500017	Wear ring	1
	500018	U-cup	1
	500019	O-ring	1
	500023	O-ring	1
	500030	U-cup	1

601035	Fluid section repair kit		
	Fits: 820301, 820302, 820303		
	Components include		
	Part #	Description	Qty
	500033	Seal retainer	1
	500034	Packing	2
	500035	Seal expander	1
	500036	Shaft wiper ring	1
	500041	Gasket	1
	500042	O-ring	1
	500053	Gasket	2
	500054	Lower roll pin	1
	500055	Upper roll pin	1
	500056	Viton O-ring	1
	500061	Piston packing cup	1
	500063	U-cup	1
	500064	Wear ring	1
	500066	O-ring	2
500237	O-ring; OP242CD ONLY	1	

5.0 TROUBLESHOOTING

Problem	Causes	Recommended Solutions
Pump does not operate.	Air supply or pressure is inadequate. Air lines restricted.	Increase air pressure. Check for any restrictions in air line.
	Dispensing valve is not open or clogged.	Open and/or clear foot valve.
	Clogged fluid lines, valves, hoses or damaged air motor.	Follow pressure relief procedure to clear obstruction. Service air motor. Replace parts as necessary.
	Depleted or exhausted fluid supply.	Refill fluid. Prime system or flush it.
	Worn or damaged air motor gasket, packing, seal, etc	Service air motor. Replace parts as necessary.
Non-stop air exhaust.	Intake valve or packing worn off.	Replace worn parts
Erratic pump operation.	Intake valve is not completely closed.	Clear obstruction and service pump. Replace parts as necessary.
	Held open or worn intake valve.	Clear obstruction and service pump. Replace parts as necessary.
Low output on upstroke.	Held open or worn piston valve.	Clear obstruction and service pump. Replace parts as necessary.
Low output on down stroke.	Restriction in air lines or air pressure low.	Increase air pressure or supply.
	Closed or clogged valves.	Open valve or clear valve.
Low output on both strokes.	Fluid supply is insufficient or exhausted.	Refill fluid. Prime system or flush it.
	Obstructions in fluid lines, hoses, valves, etc.	Follow pressure relief procedure, then clear obstruction.

6.0 TECHNICAL SPECIFICATIONS

Technical Data

Fluid Ratio	2.25:1
Maximum Output Flow (intermittent)	7.5 gpm (28.4 lpm)
Maximum Output Flow (continuous)	5.0 gpm (18.9 lpm)
Maximum Output Pressure	405 psi (27.9 bar)
Maximum Air input Pressure	180 psi (12.4 bar)
Air inlet Port	1/4 npt (f)
Fluid Outlet Port	3/4 npt (f)
Rod & Piston Packings	PTFE
Other Seals	Viton
Rod & Cylinder	Stainless Steel
Other Wetted Parts	Stainless Steel

Dimensions

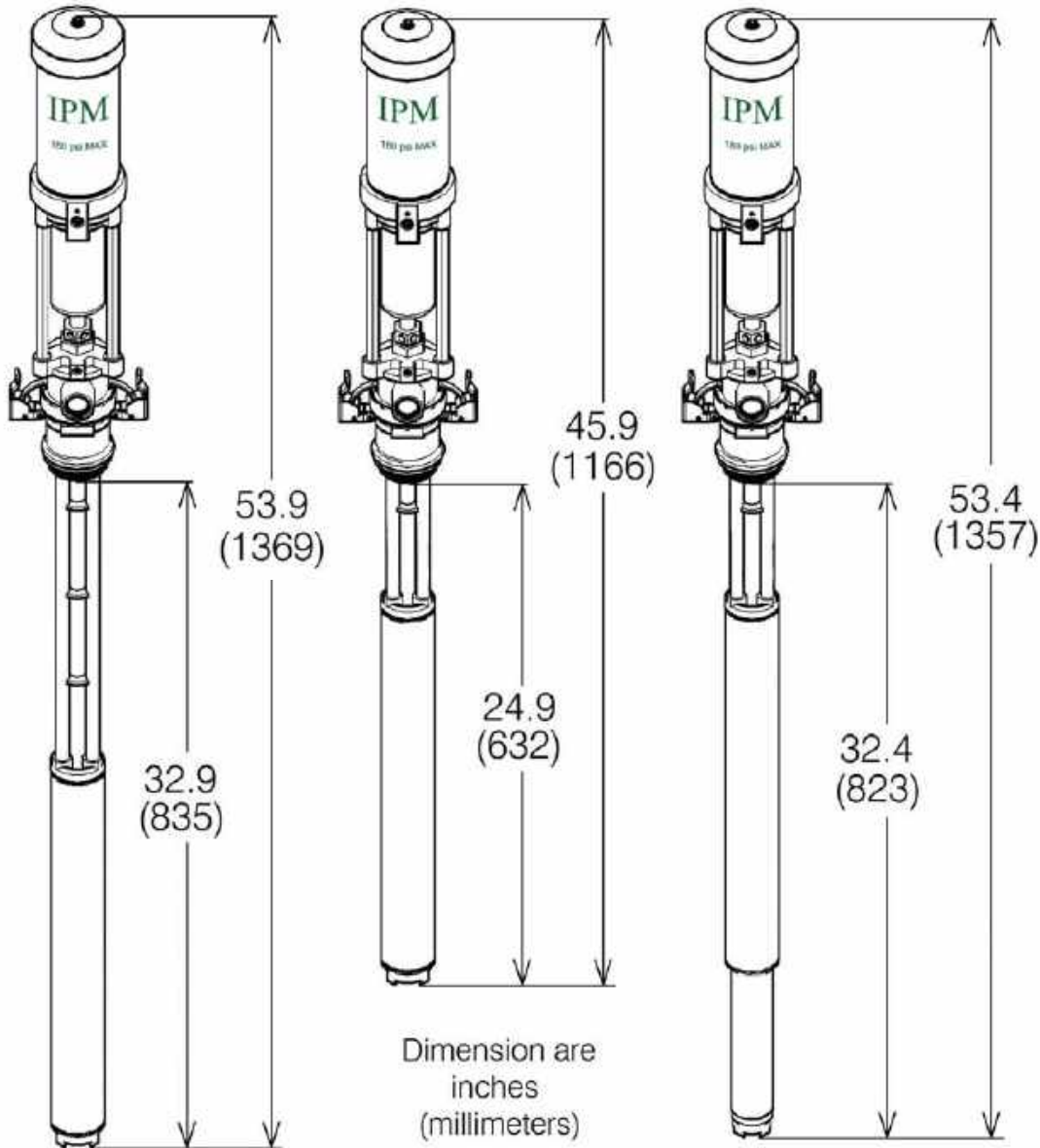

820301

820302

820303

7.0 PERFORMANCE

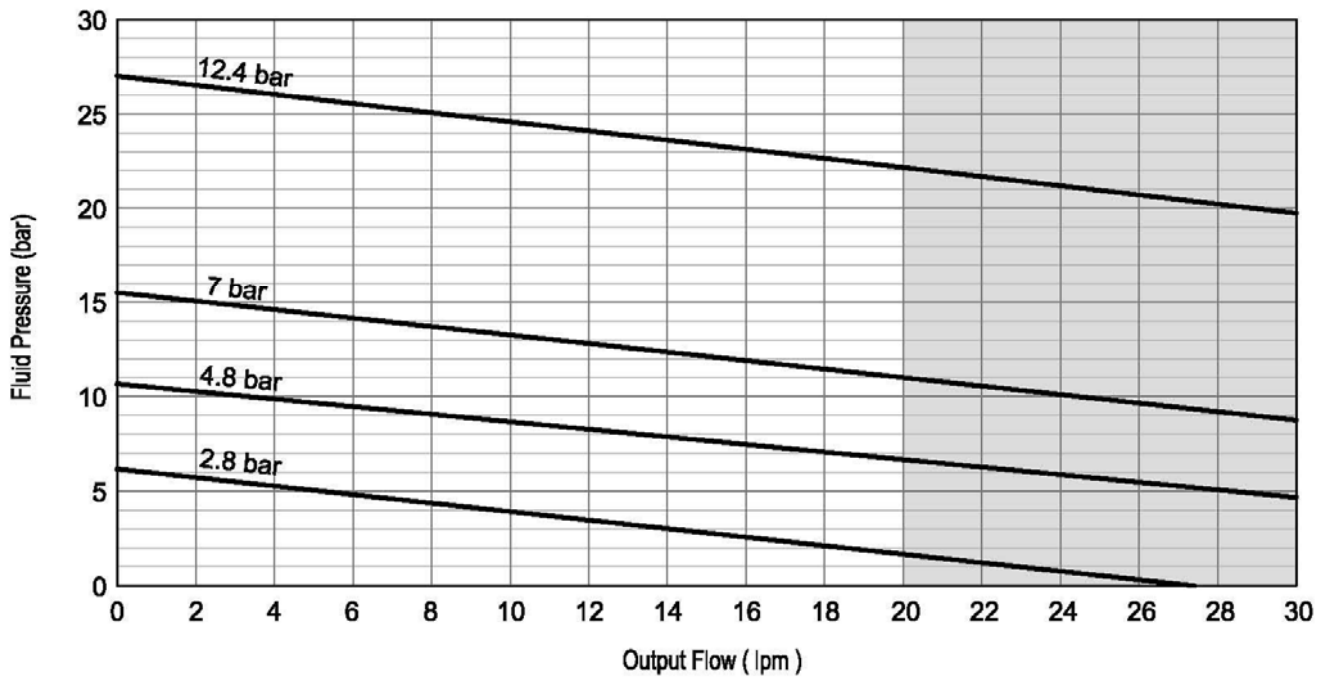
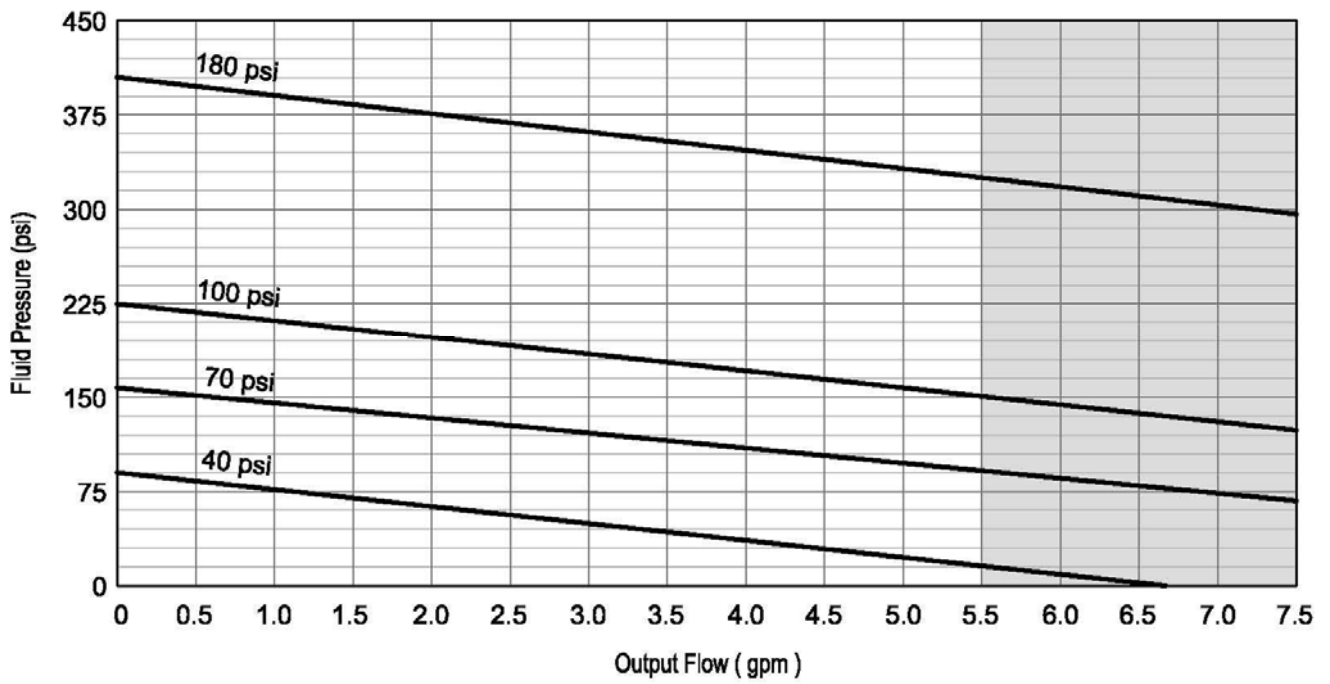

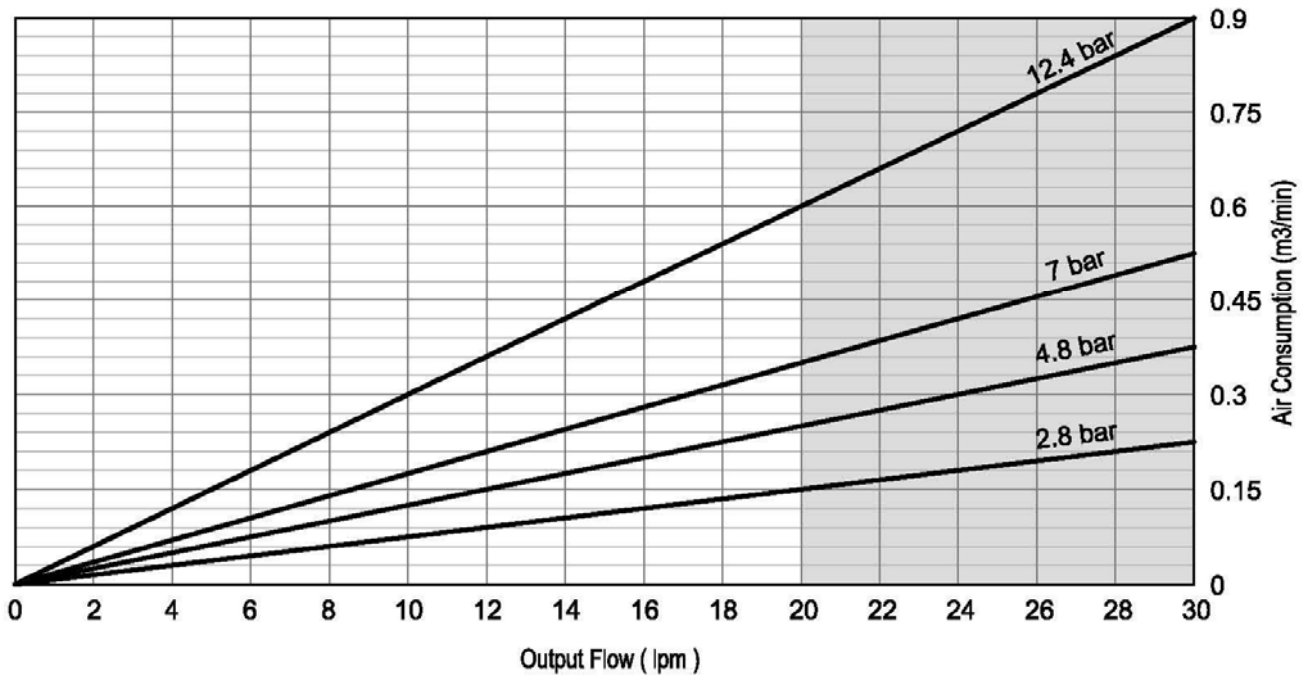
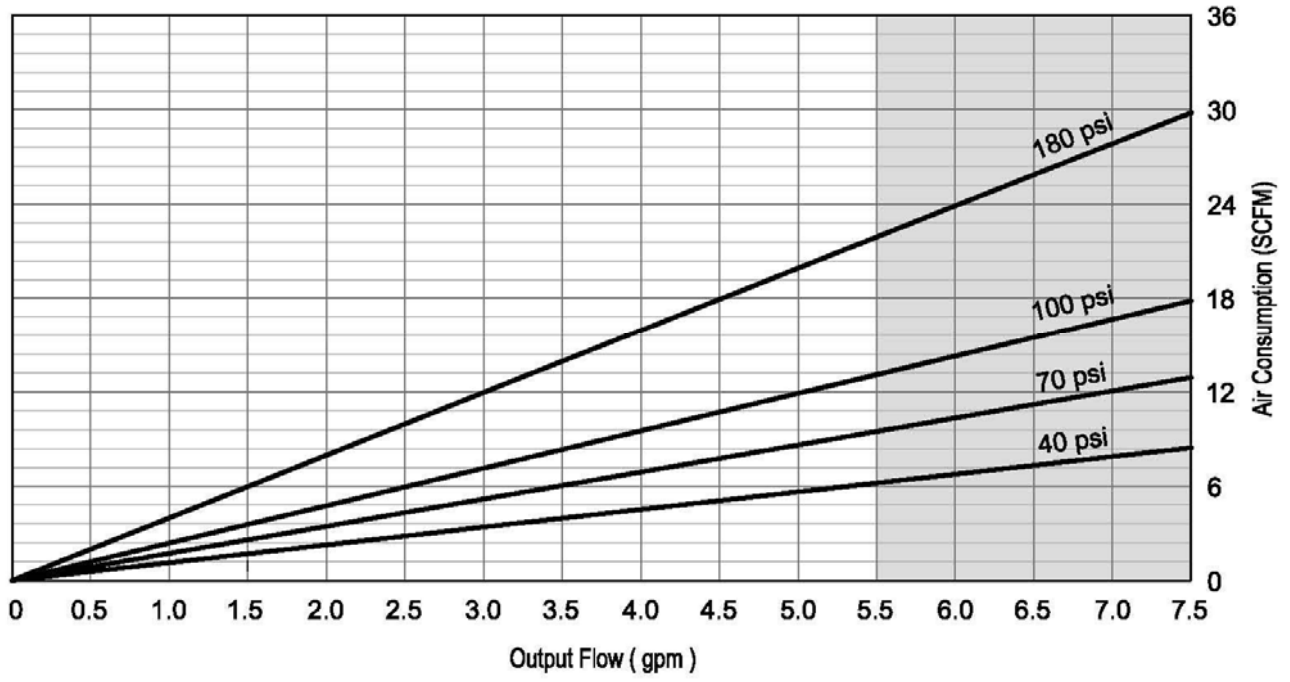

8.0 WARRANTY AND DISCLAIMER

WARRANTY

International Pump Manufacturing, Inc. (hereafter designated IPM) warrants the equipment it manufactures to be free of defects in materials and workmanship for a period of one (1) year from the date of sale from IPM to an authorized IPM distributor or to the original end user and/or purchaser. IPM will, at its discretion, repair or replace any part of the equipment proven to be defective. This warranty applies only when the equipment is used for the intended purpose and has been installed, operated and maintained in accordance with written operating procedures.

A condition of the warranty is the prepaid return of the equipment to an authorized distributor of IPM who shall provide verification of the warranty claim. IPM will repair or replace free of charge any parts found and verified to be defective or damaged upon receipt of equipment. Shipping will be prepaid for the repaired or replaced parts under warranty. Should inspection of the equipment reveal no defects in material or workmanship repairs will be made at the standard IPM rate, which will include parts, inspection, labor, packaging and shipping.

The warranty does not apply nor shall IPM be liable for damage, operational wear, malfunction of equipment caused by improper installation, misuse, chemical abrasion or corrosion, operator negligence, accident, tampering or altering of equipment, lack of improper maintenance and/or by substitution of non-IPM parts. Additionally, IPM shall not be liable for nor does the warranty apply to operational wear, damage or malfunction caused by incompatibility of accessories, components, structures, equipment or materials not supplied by IPM. The warranty does not apply to nor will IPM be responsible for the improper operation, maintenance, design, manufacture, installation of components, accessories, equipment or structures not supplied by IPM.

The warranty is void unless the Warranty Registration Card is properly completed and returned to IPM within ONE (1) month of the date of the sale.

LIMITATIONS AND DISCLAIMERS

This warranty is the sole and exclusive remedy for the purchaser. No other warranties, expressed or implied, warranties for fitness of purpose or merchantability, or non-contractual liabilities are made by IPM, including product liability, whether on negligence or a strict liability basis. Liability for directly special or non-contractual damages or loss is expressly excluded and denied. IPM's liability shall in no case exceed the amount of the purchase price.

IPM does not warrant and disclaims implied warranties of merchantability and fitness for a particular purpose, components, accessories, equipment, materials sold but not manufactured by IPM. These parts (valves, hoses, fittings, etc.) are subject to the provisions within the warranty of the actual manufacturer of these items. IPM will provide reasonable assistance with warranty claims on these items.



**3107 142nd Avenue East Suite 106
Sumner, WA 98390
U.S.A.**

**TEL: (253) 863 2222 FAX: (253) 863 2223
Website : www.ipmpumps.com**

Updated Jun 2016